



SKYLIGHT INSTALLATION & ELECTRICAL GUIDE

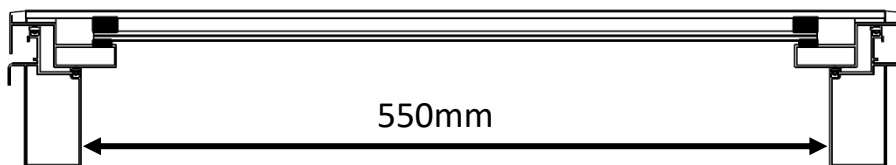
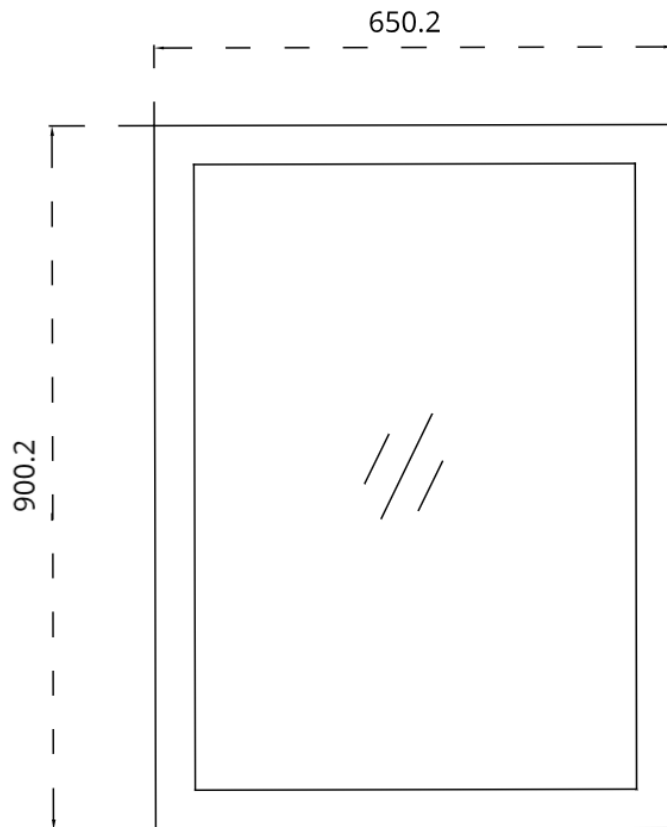

TABLE OF CONTENTS

Skylight models and frame opening sizes	4 – 14
Skylight installation	15 – 16
Skylight tiled flashing installation	17 – 18
Flat roof flashing and installation of roof cladding	19
Tiled roof installation diagram	20
Metal roof installation diagram	21
Flat roof installation diagram	22
Electric blind installation and wiring	23
Electric blind remote programming	24
Electric wiring of opening skylight	25
Electric opening skylight controller and remote programming	26 - 27
Solar rain sensor programming	28
Solar-powered skylight module installation	29 - 30
Solar-powered skylight module programming	31
Connecting blind to Wi-Fi and mobile app	32
Connecting electric opening skylight to Wi-fi	33
Skylight shaft cladding and wet area installations	34
Flyscreen installation	35
Trouble shooting	36
Warranty information	37 – 38
Supplied components	39

MODEL:	VD650900	VDL900650
	ED650900	
	SD650900	

SIZE: 650mm x 900mm



Standard installation frame opening size required: 550mm x 800mm

Frameless installation frame opening size required: 480mm x 730mm

MODEL:	VD6501200	VDL1200650 (landscape)
	ED6501200	EDL1200650 (landscape)
	SD6501200	SDL1200650 (landscape)

SIZE: 650mm x 1200mm

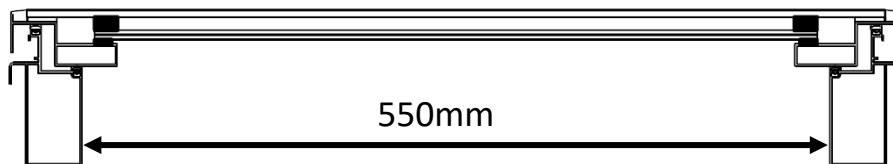
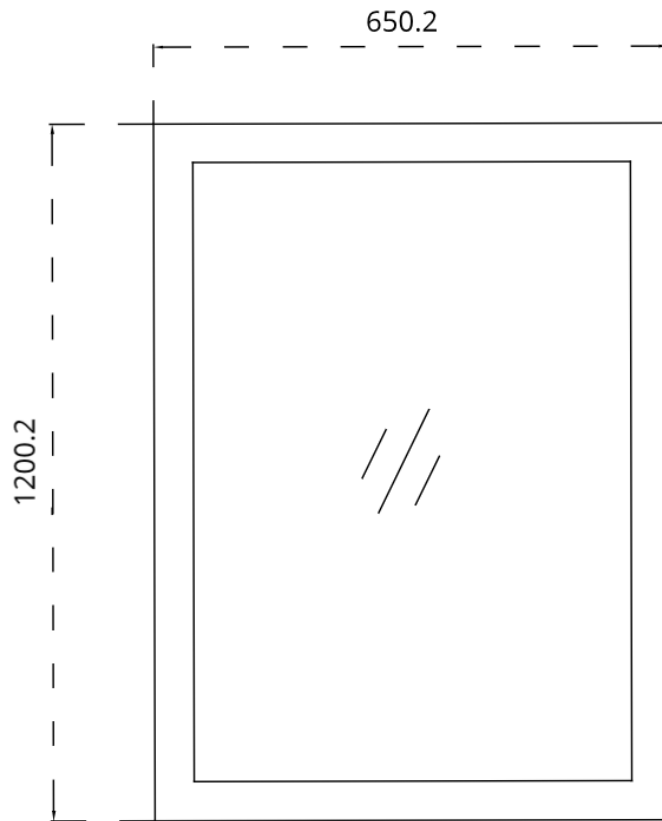

Standard installation frame opening size required: 550mm x 1100mm

Frameless installation frame opening size required: 480mm x 1030mm

MODEL:	VD950950
	ED950950
	SD950950

SIZE: 950mm x 950mm

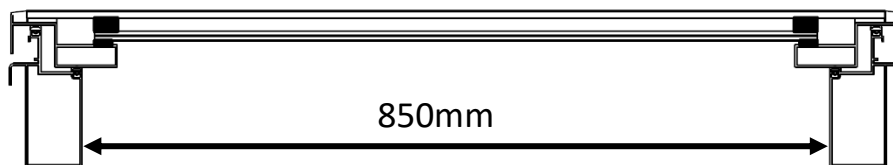
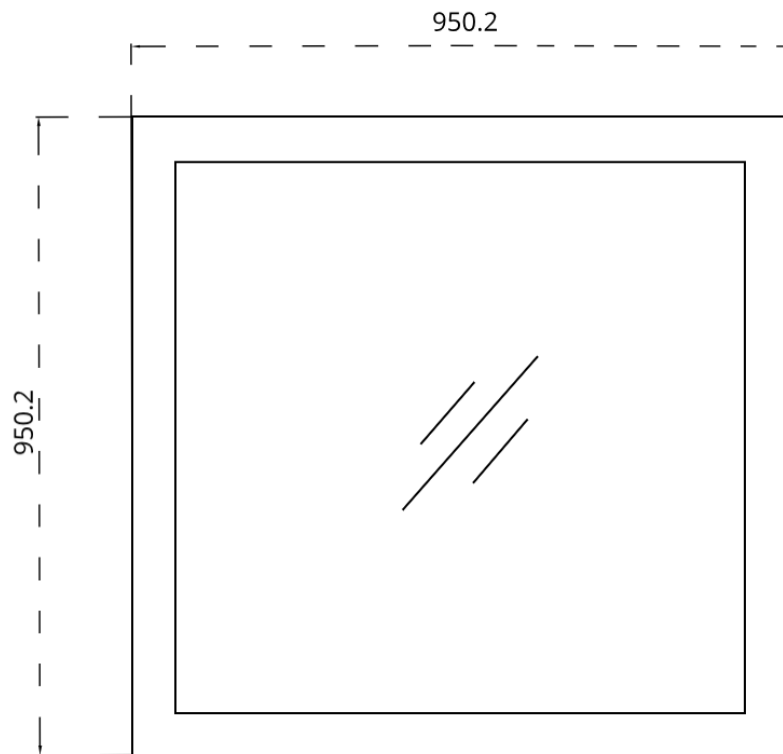

Standard installation frame opening size required: 850mm x 850mm

Frameless installation frame opening size required: 780mm x 780mm

MODEL:	VD9501200	VDL1200950 (landscape)
	ED9501200	EDL1200950 (landscape)
	SD9501200	SDL1200950 (landscape)

SIZE: 950mm x 1200mm

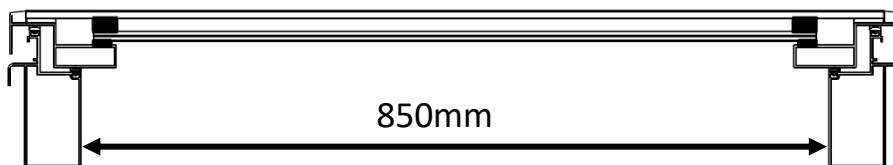
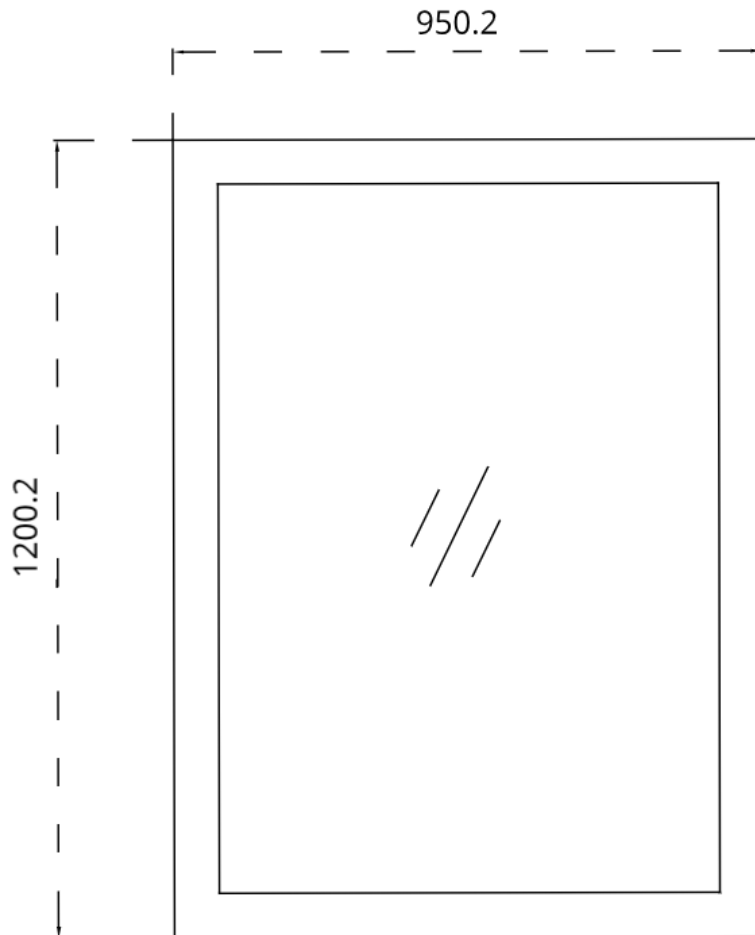

Standard installation frame opening size required: 850mm x 1100mm

Frameless installation frame opening size required: 780mm x 1030mm

MODEL:	VD7501600
	ED7501600
	SD7501600

SIZE: 750mm x 1600mm

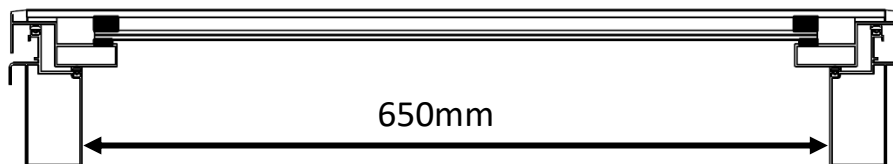
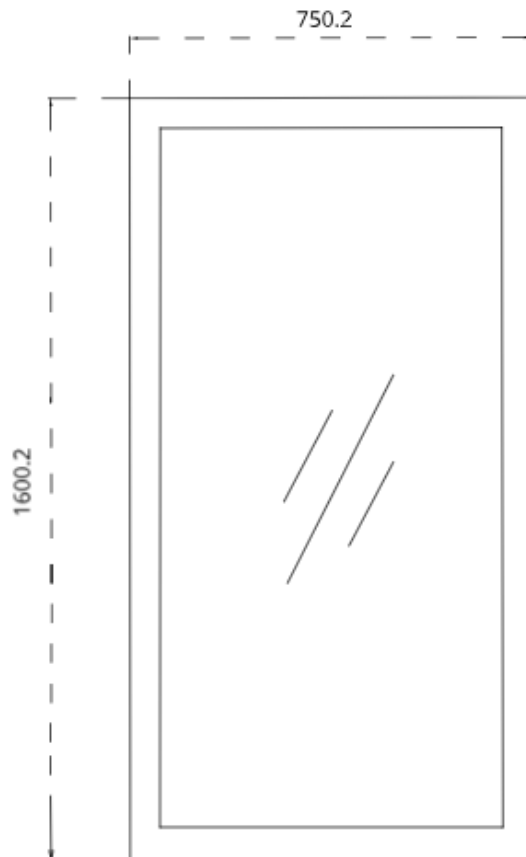

Standard installation frame opening size required: 650mm x 1500mm

Frameless installation frame opening size required: 580mm x 1430mm

MODEL:	VD7501900
---------------	------------------

SIZE: 750mm x 1900mm

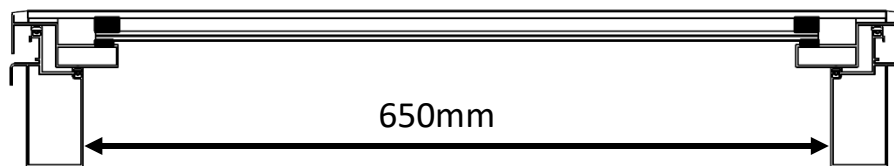
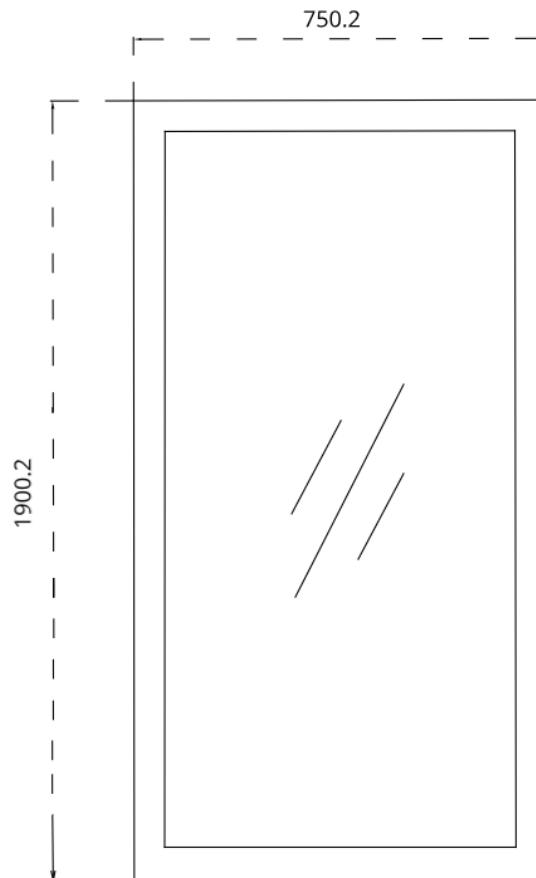

Standard installation frame opening size required: 650mm x 1800mm

Frameless installation frame opening size required: 580mm x 1730mm

MODEL:	VD7502500
---------------	------------------

SIZE: 750mm x 2500mm

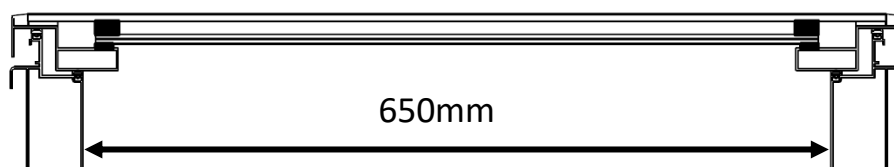
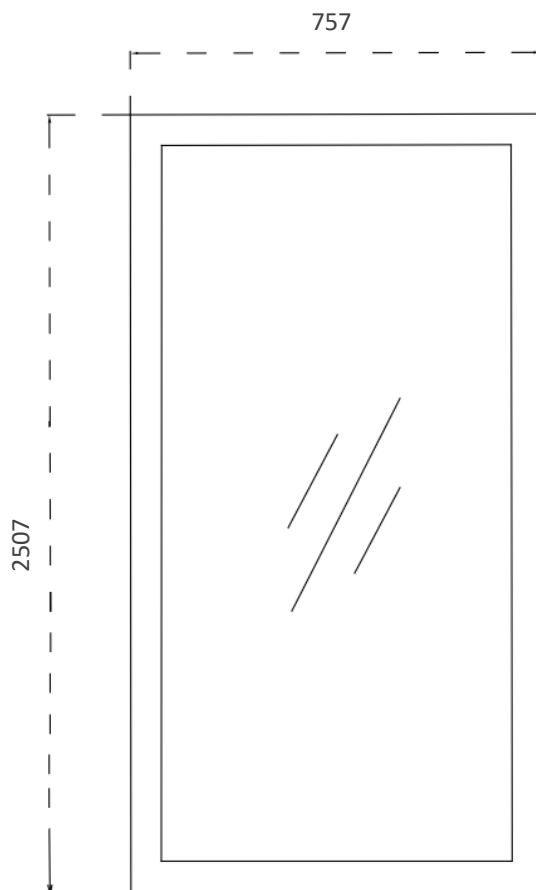

Standard installation frame opening size required: 650mm x 2400mm

Frameless installation frame opening size required: 580mm x 2330mm

MODEL: VDI200I200

SIZE: 1200mm x 1200mm

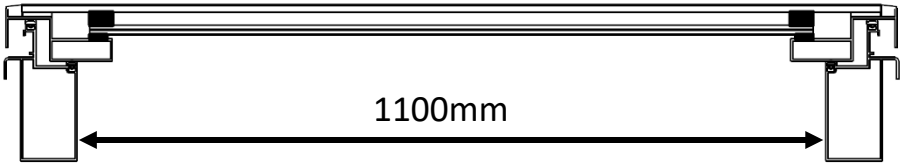
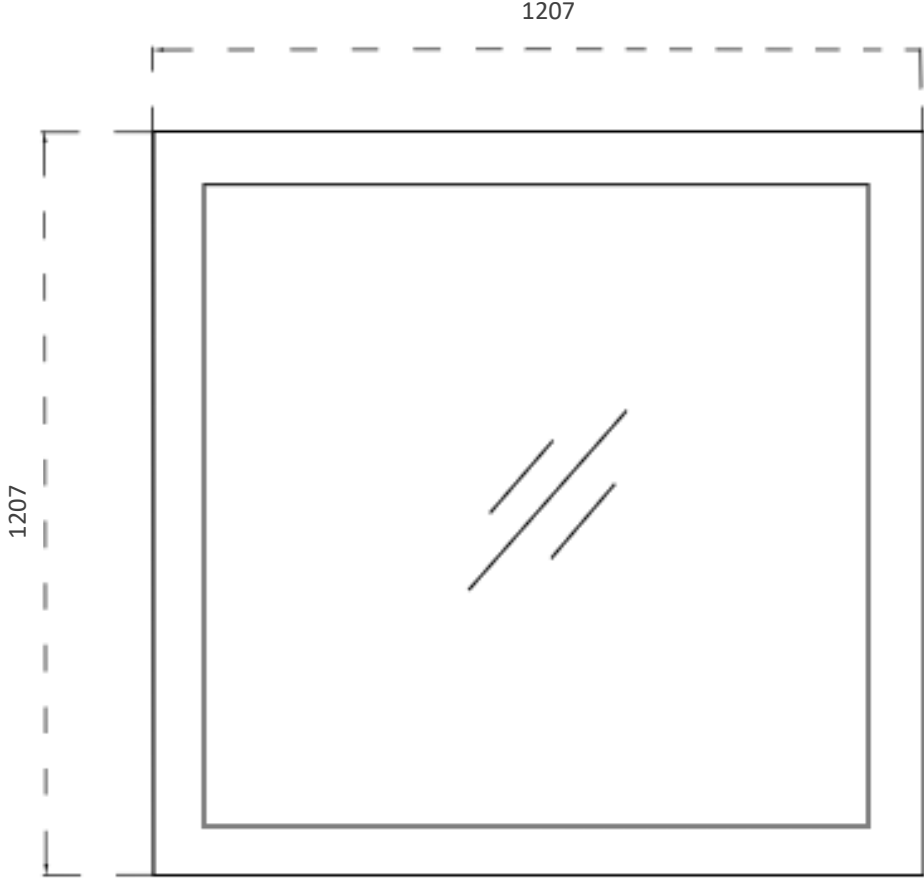

Standard installation frame opening size required: 1100mm x 1100mm

Frameless installation frame opening size required: 1030mm x 1030mm

MODEL:	VDI400I400
---------------	-------------------

SIZE: 1400mm x 1400mm

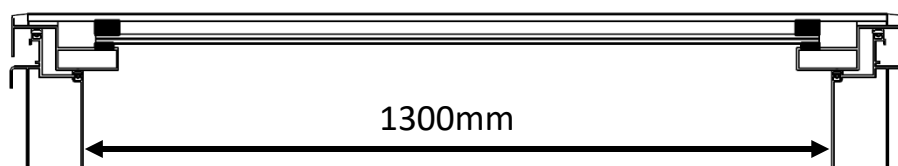
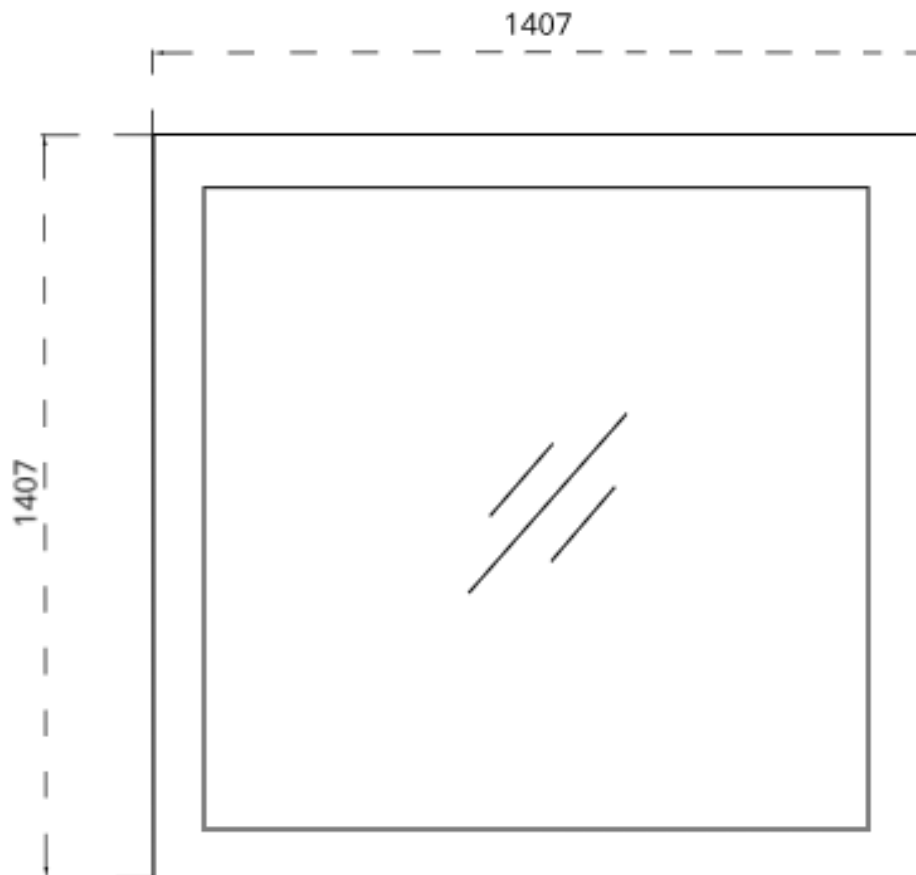

Standard installation frame opening size required: 1300mm x 1300mm

Frameless installation frame opening size required: 1230mm x 1230mm

MODEL: VDI 1001900

SIZE: 1100mm x 1900mm

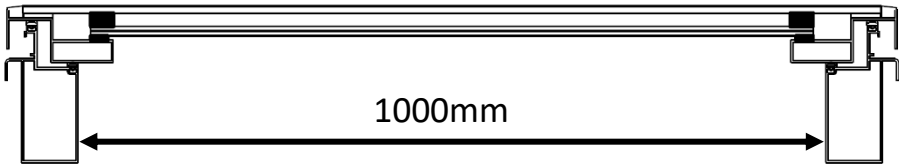
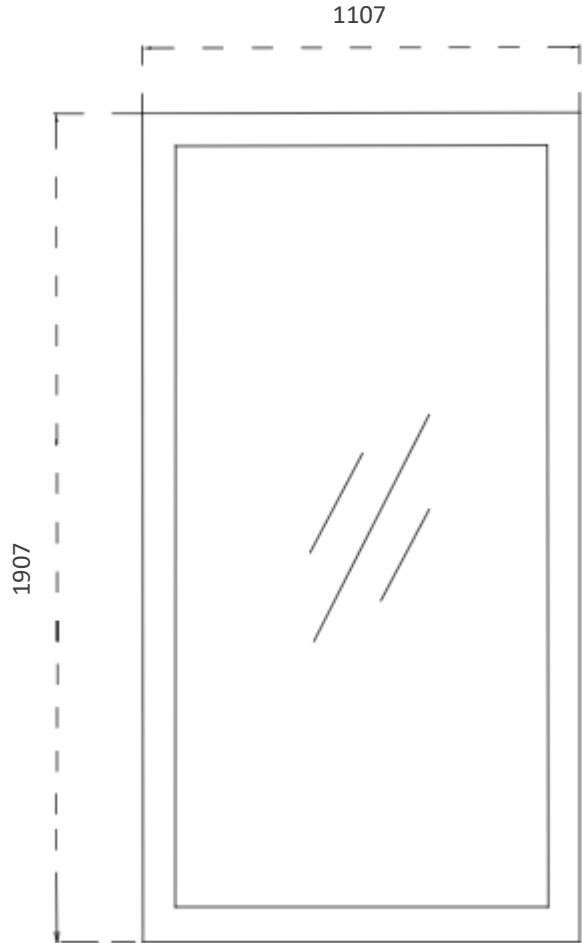

Standard installation frame opening size required: 1000mm x 1800mm

Frameless installation frame opening size required: 930mm x 1730mm

MODEL: VDI 1003100

SIZE: 1100mm x 3100mm

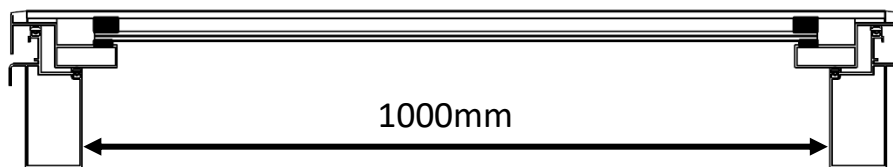
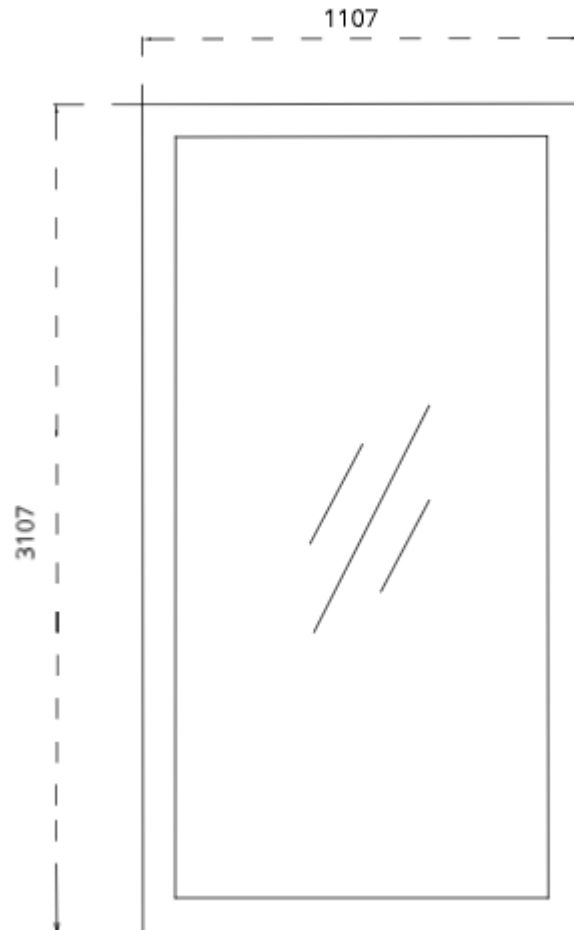

Standard installation frame opening size required: 1000mm x 3000mm

Frameless installation frame opening size required: 930mm x 2930mm

SKYLIGHT INSTALLATION

Note: Installation must be carried out by a competent tradesman such as a registered carpenter or licenced roof plumber. If structural members of the roof need to be adjusted to suit the opening size required consult a structural engineer before amending frame opening. When lining the internal shaft of the skylight for frameless applications ensure the cladding does not touch the glass and has a minimum 5mm gap between top edge of cladding and glass. Skylights are designed to be installed at a recommended minimum 3 – 45 degrees.

Frame opening to size required as per the notes regarding frame opening sizes noted on pages 4 - 9. The skylight must be supported by roof rafters/battens, trim out all four sides as necessary. Check opening is square on each corner



1. Install roof battens 5mm short of the frame opening size on all four sides. *(Skylight is fixed into position on top of roof battens with a 10mm packer for a tiled roof. *Metal roof skylight needs to be packed up to thickness of the roof sheet)*

2. Install supplied mounting brackets using 16mm metal self-tapping screws into the skylight frame as per picture. Install 2 brackets on each side 100mm from each end of the skylight and if required 2 brackets in the centre top and bottom depending on size of skylight. And or in line with roof batten as required.

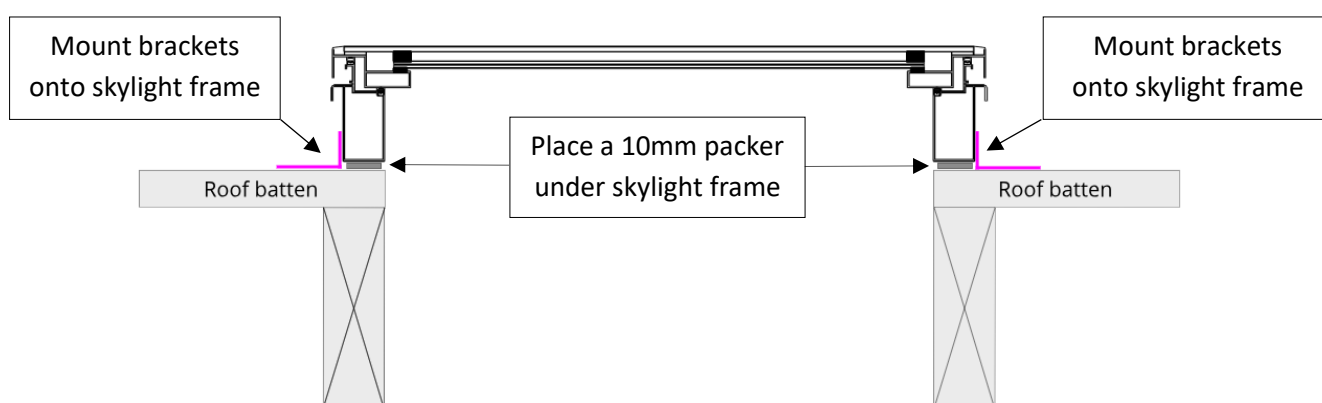

NOTE: *(For metal roofs only, pack the skylight up above the roof batten the thickness of the roofing sheet material being used so that the custom flashing (not supplied by Vivid Skylights) has a minimum 70mm upstand to comply with Australian plumbing regulations.)*

3. Place skylight on roof frame opening, ensuring it is in the correct position from underneath to suit internal cladding of skylight shaft. (For electric opening skylights the motor should be on the lower side of the roof)



4. Using the supplied 30mm timber screws fix the brackets into position.



INSTALLATION OF FLASHING KIT - TILED ROOF

1. Start with the bottom flashing slide it right up under the lip of the skylight. Using supplied 16mm metal self-tapping screw, screw through the side of the flashings into the left and right side of the skylight frame only securing the flashing into position. Ensure it stays tight up under the lip of the skylight frame on each side.

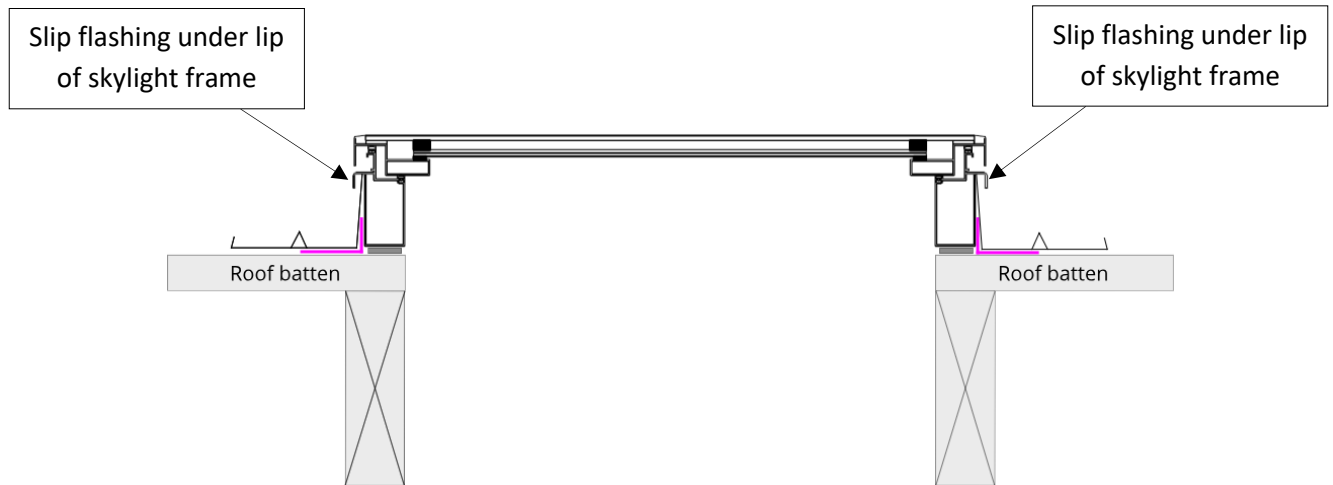

2. Next install the side flashings under the skylight lip and **OVER** the bottom flashing and using screws to secure it into position.



3. Fold tab of bottom flashing over edge of side flashing to hold in place.

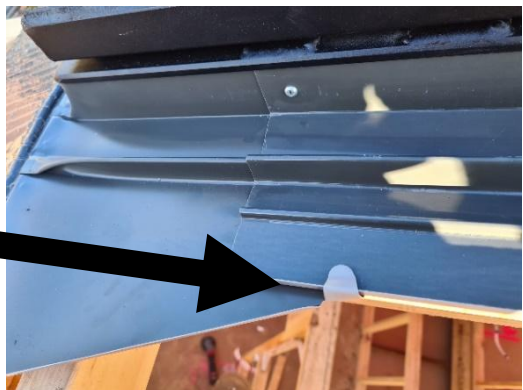

4. Finally install the top flashing under the lip of the skylight and OVER the side flashings. (Do not screw any fixing down through the flashing as it may cause it to leak)

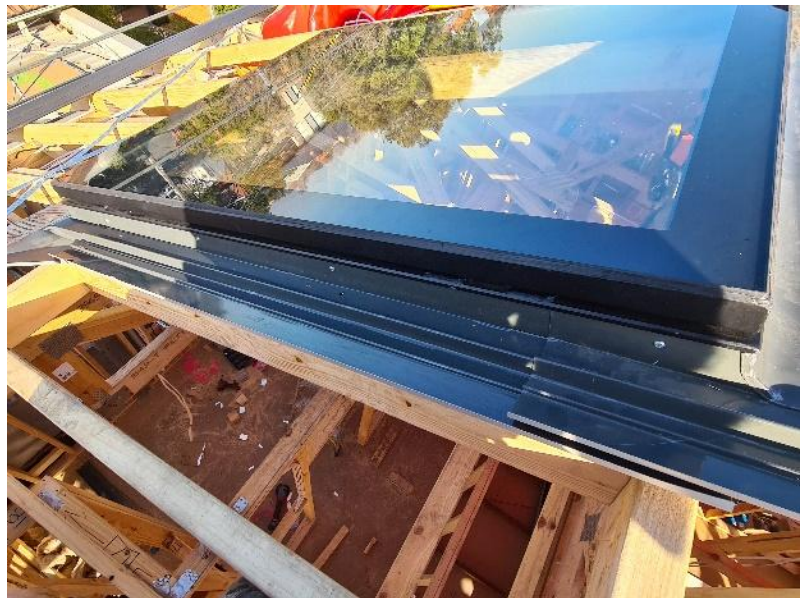

5. Wipe down skylight frame and side edge of flashings ensuring they are dry and dust free.

6. Using roofing silicone, run a thick bead of silicone under the lip of the skylight to seal the skylight and roof flashing on all four sides. (This applies for installation on metal roofs with custom flashings)



FLAT ROOF FLASHINGS

A custom flashing is required to install skylights on metal, flat or low pitch roofs (less than 15 degrees). (Vivid Skylights do not provide custom flashings). Custom flashings must be installed by a registered roof plumber and sealed under lip of skylight.

INSTALLING ROOF CLADDING

1. Ensure roof battens are installed under flashing kit to support it.
2. Tiles must be cut 50 - 100mm from the bottom of the skylight frame to ensure it doesn't push up the bottom flashing and cause pooling of water on the flashing. (If tiles are still high, chamfer off the top edge of the tile to flatten it off).
3. Cut the remaining tiles 15 - 30mm from the edge of the skylight frame.
4. Once complete using a rubber mallet lightly tap the bottom flashing to form the profile of the roofing it has been installed to.



TILED ROOF

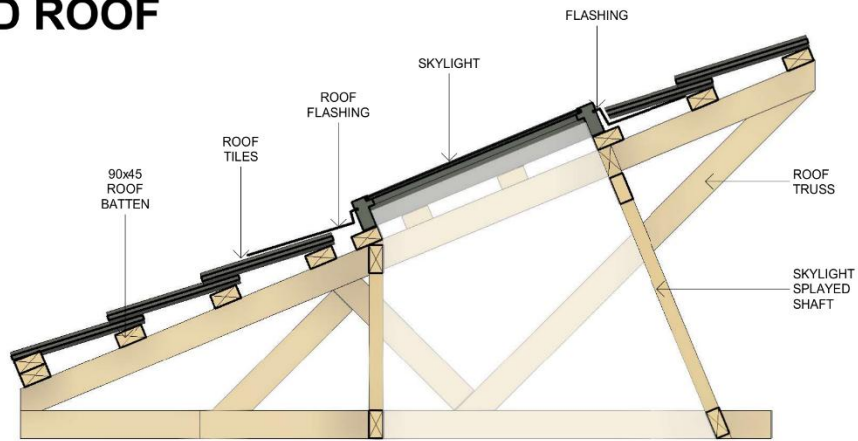

TILED ROOF SECTION 1

SCALE: 1 : 20

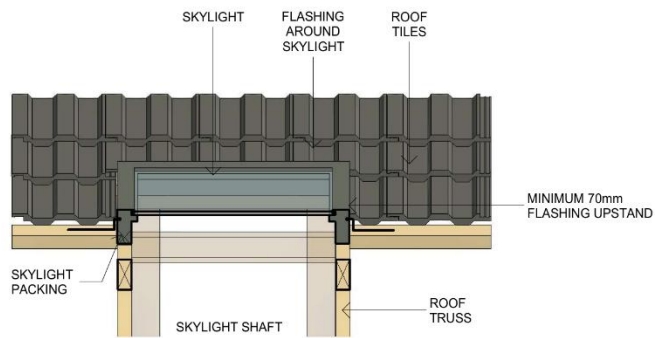

TILED ROOF SECTION 2

SCALE: 1 : 20

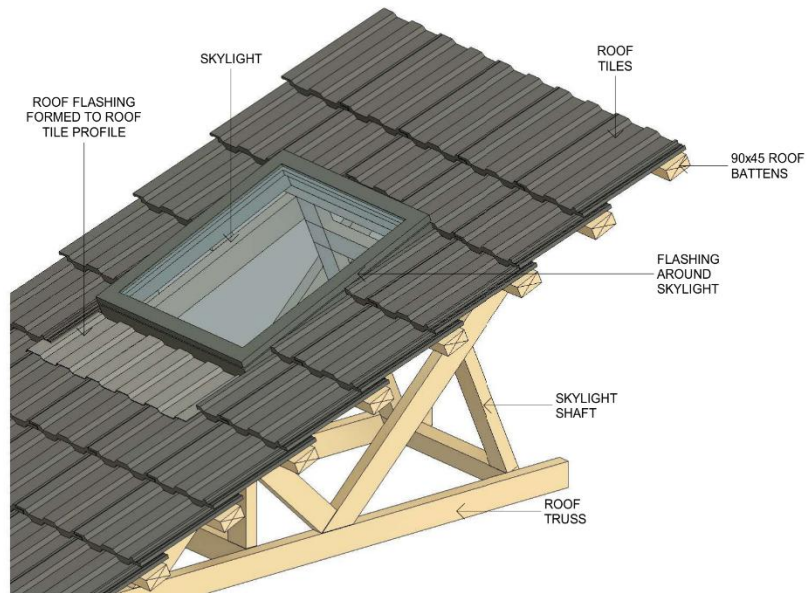

TILED ROOF 3D

SCALE:

METAL ROOF

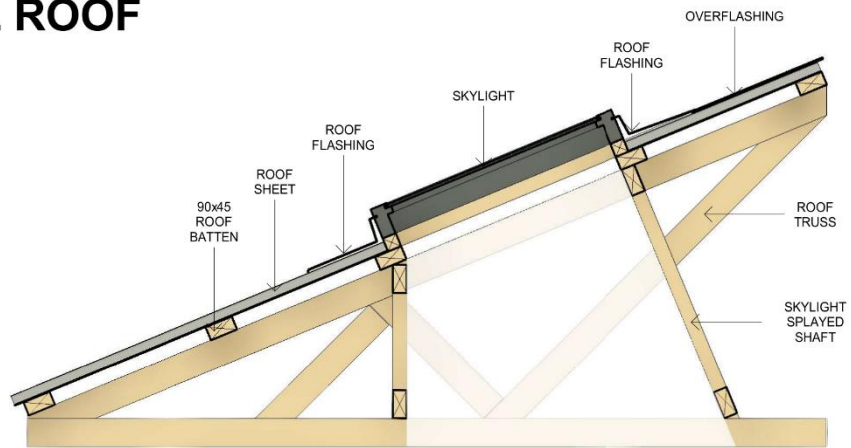

METAL ROOF SECTION 1
SCALE: 1 : 20

METAL FLASHING TO HAVE SLIGHT BEND OVER RIBS OF CORRUGATED IRON ROOF SHEETS

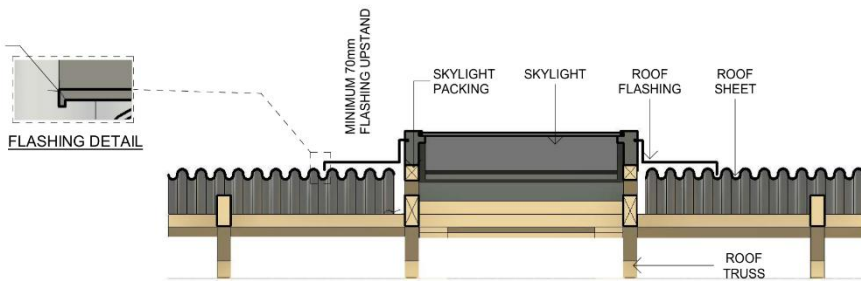

METAL ROOF SECTION 2
SCALE: 1 : 20

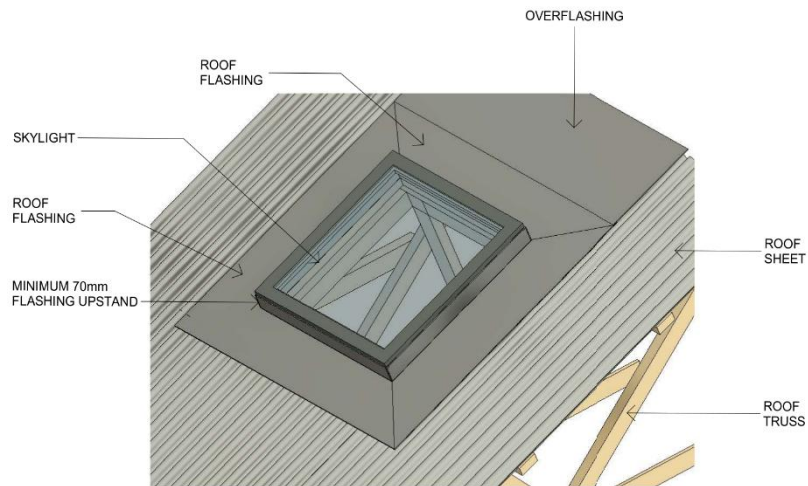

METAL ROOF 3D
SCALE:

FLAT OR LOW PITCH ROOFS

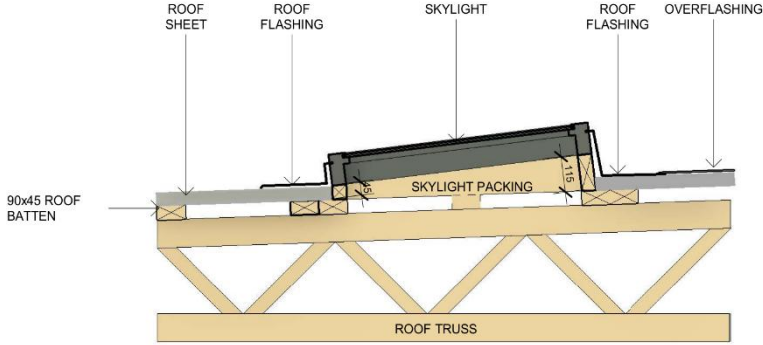

FLAT ROOF SECTION 1
SCALE: 1 : 20

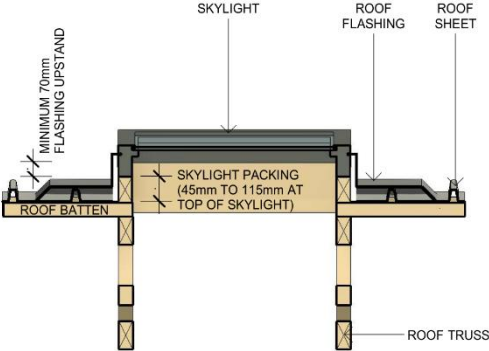

FLAT ROOF SECTION 2
SCALE: 1 : 20

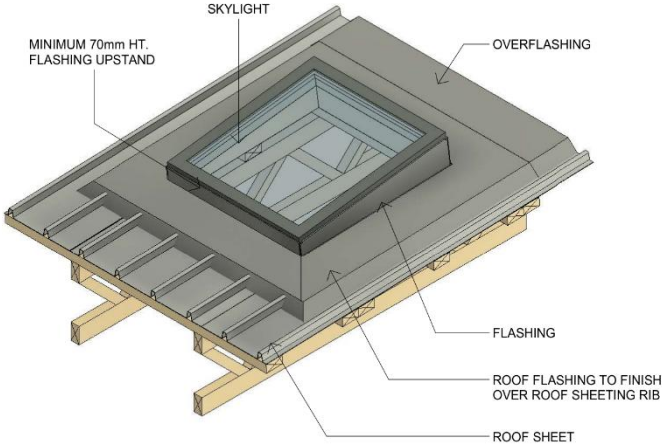

3D FLAT ROOF
SCALE:

ELECTRIC BLIND INSTALLATION AND WIRING

Note: Blind cable is at the bottom of the blind. Blind closes from the top going down to be in the closed position.

Note: Vivid Skylights does not warrant and does not recommend the installation of skylight blinds in high moisture areas such as a bathrooms and laundries which can cause the blind fabric to malfunction over time.

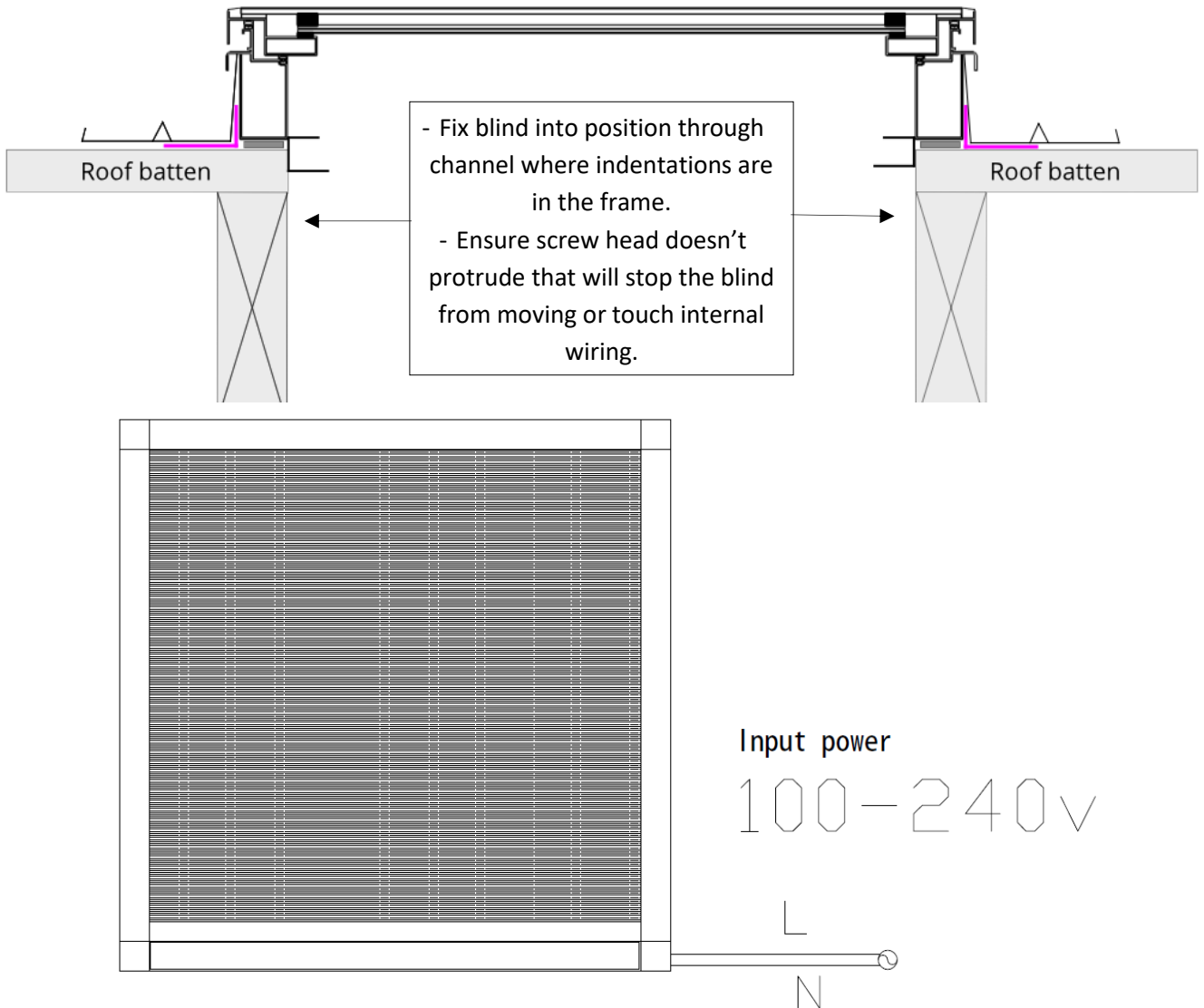

Note: Always use a licensed electrician to connect blind wiring. The blind has an internal transformer. 240V can be connected to the blind cable. Install an isolator switch for each blind. For multiple blinds, each blind needs to be able to be switched off separately for it to be programmed otherwise it will be programmed on the same channel.

Note: Electric Blind remotes supplied are already preprogrammed for the blind. If required a 7mm hole can be drilled through the bottom of the skylight frame to thread the blind cable through (and or through timber shaft framing if it's an electric skylight).

*****ELECTRICIANS FOLLOW THE INSTRUCTIONS*****

**Electric blind remote programming with electric opening skylight.
(And reprogramming standard blind remote)**

Press “left or right buttons” on remote control to shift between different channels such as channel 1, 2, 3, 4 etc. Choose a channel that you want to program for the blind, (*Please note: The blind can't be on the same channel as an electric opening skylight*)

Note: If it is also an opening skylight the blind will need to be on a separate channel to the programming of the opening skylight.

1. Connect power for the electric blind, once power is on the blind motor will vibrate a little, select which channel you want it programmed to.
2. Then press P2/S2 key at the back of the remote control for 2-3 seconds. (open back cover) Blind will move a little at this time then press P2/S2 again.
3. Flip the remote over to the digital display side and press the “down” button Programming of blind is now complete. (wait 5 seconds before using remote)



Using the remote

1. Select the channel the blind has been programmed to using the “left or right buttons” such as channel 1 or 2 or 3 etc.
2. Then press the “up or down buttons” to raise or lower the blind.
3. To stop the blind press the centre button in between the up and down buttons.

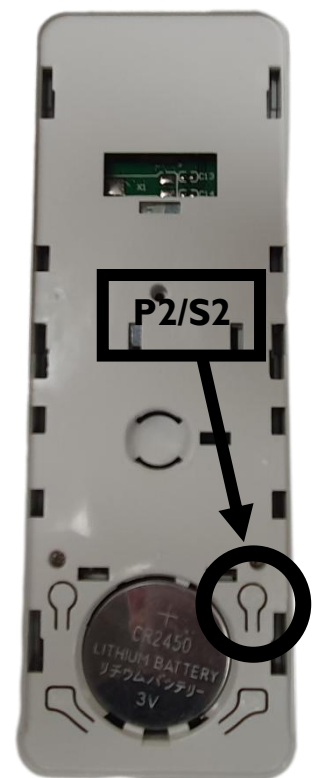

Click on the link for our YouTube explainer video
<https://youtube.com/shorts/pwntz2aLtQg?feature=share>

If installing a wifi connectable blind it is advisable to extend the CAT6 cable via an adapter to an accessible location for connecting to the wifi at fit-off stage to make it easier.

ELECTRIC WIRING OF OPENING SKYLIGHTS

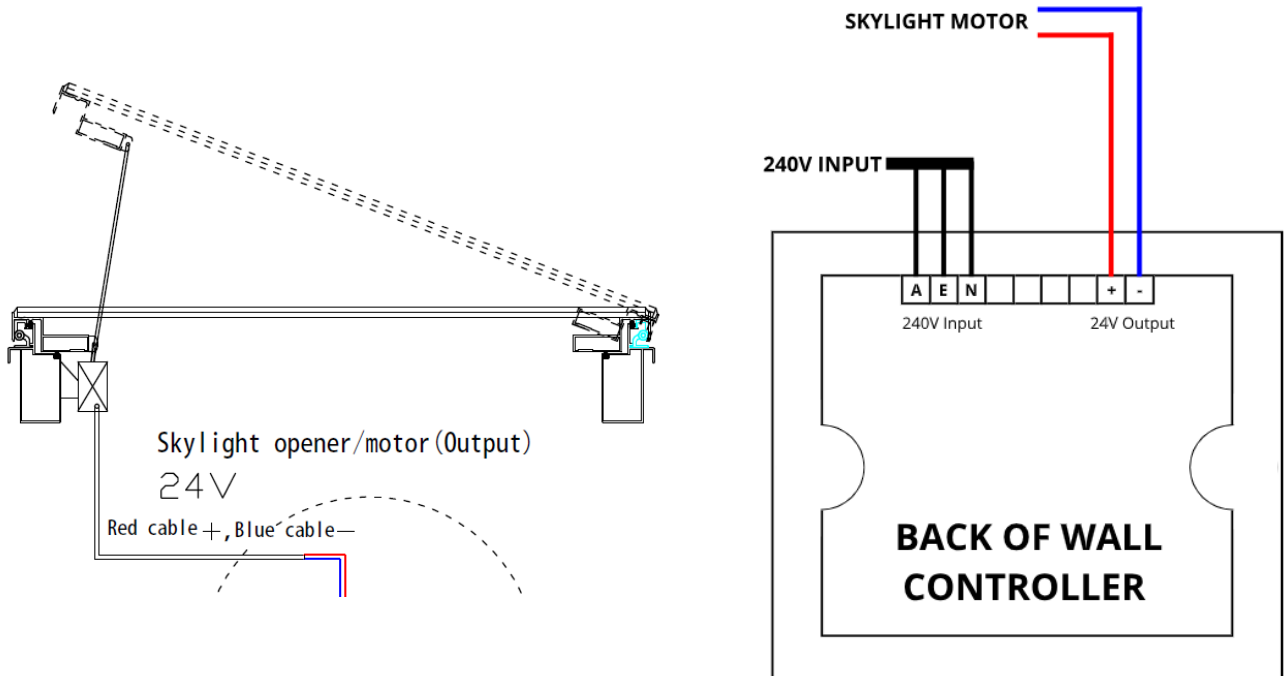

Important Notes:

- **When installing skylight, the motor is to be on the lower side of the roof**
- **The power input terminal and output terminal cannot be reversed, otherwise the control box will burn out.**
- **The skylight motor is 24V and the 110 – 240V voltage cannot be directly connected to it otherwise the motor will burn out**
- **Always use a licensed electrician to connect wiring of opening skylights.**
- **Install an isolator switch for the 240v power before the wall controller**
- **It is highly recommended that the skylight is closed when exiting the building in case there is a power outage in your area, when rain starts to fall.**

ELECTRIC OPENING SKYLIGHT CONTROLLER AND REMOTE PROGRAMMING

*****ELECTRICIANS FOLLOW THE INSTRUCTIONS*****



Skylight wall controller



Remote

1. On the remote press “left or right buttons” on remote control to shift between different channels such as channel 1, 2, 3, 4 etc. Choose a channel that you want to program for the opening skylight.

Note: All electric skylights have been pre-programmed for channel 1, skylights can normally be opened and closed on channel 1. Max motor running time is 5 minutes. Max (x2) skylights can be programmed to (x1) wall controller

Note: If there is also a blind being installed with the opening skylight, it will need to be on a separate channel to the programming of the blind.



2. Ensure power is connected. Press middle “stop button” for 5 seconds on skylight controller, indicator light start flashing.

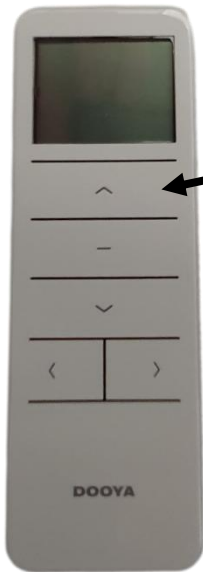

3. Select which channel you want to set it on, then press “UP” on the remote for 0.5 seconds.

4. The wall controller indicator light will then flash x3 times. Programming is now complete.

Click on the link for our YouTube explainer video
<https://youtube.com/shorts/Rv54VVQBahU?feature=share>

Deleting all previous programming memory

1. Connect power for skylight
2. Press middle “stop and close button” on wall controller simultaneously for 5 seconds, it will then make x3 shorts “beeps”. Previous programming memory is now deleted. To reprogram follow programming steps from previous section of how to program skylight controller and remote.



Click on the link for our YouTube explainer video
<https://youtube.com/shorts/XugHUA9Z3ZQ?feature=share>

Deleting only 1 program in remote memory

1. Connect power for skylight. Press “Stop” on wall controller for x5 seconds and the indicator light will start flashing, it is now in programming state.
2. On remote, select which program channel you would like to delete, then press the “Down” button on the remote for 0.5 seconds. Wall controller indicator light will do x3 short flashes. Previous programming memory is now deleted. To reprogram follow programming steps from previous section of how to program skylight controller and remote.

Click on the link for our YouTube explainer video
<https://youtube.com/shorts/TRE6JuIn0Zs?feature=share>

PROGRAMMING SOLAR RAIN SENSOR

1. Leave rain sensor in a sunny area for approximately 1 hour prior to programming so the internal rechargeable battery can charge.

NOTE: When programming the rain sensor have it with you when programming it with the wall controller (not on the roof yet).

2. Ensure power is connected to the skylight. On wall controller press “Stop” button for x5 seconds, indicator light will then start flashing.
3. Using a blunt pin or similar that will fit, on the rear of the solar rain sensor press inside the hole. Programming is now complete.
4. Place and secure rain sensor in a suitable position outside on the roof near the skylight where it will receive enough sun to charge the battery and rain during wet weather to activate the closing of the skylight. It needs to be in close proximity to the wall controller to ensure a strong signal.
5. Test rain sensor by using a spray bottle set on “misty” and lightly spray on rain sensor. (Batteries may need time to charge before it is able to operate)

Click on the link for our YouTube explainer video
<https://youtube.com/shorts/jWKbTzyiESc?feature=share>

Using the skylight remote

1. Select the channel the opening skylight has been programmed to using the “left or right buttons” such as channel 1 or 2 or 3 etc.
2. Then press the “up or down buttons” to open or close the skylight.
3. To stop the skylight press the centre button in between the up and down buttons.

SOLAR POWERED SKYLIGHT MODULE INSTALLATION

1. Leave solar panel out in the sun for a couple of hours to charge before installing on the roof.
2. Slide the mounting block down from the solar panel to release
3. Fix the mounting block in the most sunny position to the bottom of the skylight flashing lip.
(Do not mount it to the opening part of the skylight frame or any part of the roof flashing)
4. Slide the solar panel down onto the mounting block

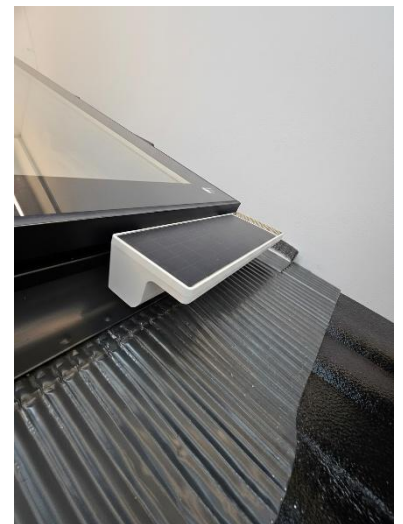
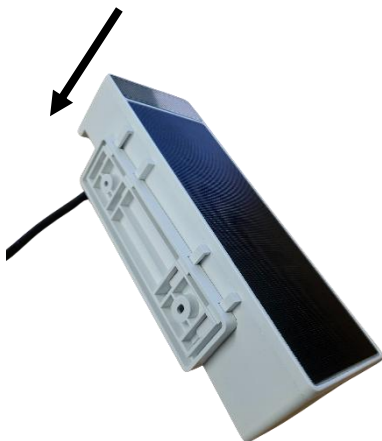

5. Open water-proof cable junction. First, thread the end cap onto the motor cable, then thread the next capping section over the cable.



6. Feed the end of the cable from the motor side into the solar panel cable connector.

Note: If required, you can unscrew the waterproof capping from the cable and drill a 7mm hole through the lower part of the skylight frame and thread the cable through the skylight frame into the roof space. **(Do not drill hole through the roof flashing)** Then, reconnect the waterproof capping onto the cable.

7. There is an N and L mark, ensure the BLACK/BLUE cable goes into the N slot and RED/BROWN cable goes into the L slot. Tighten cables in the connector with the grub screws.



8. Now screw inner water-proof capping on first, don't let it twist the cable as it is tightened up, then screw the end capping on.

9. Slide solar panel back

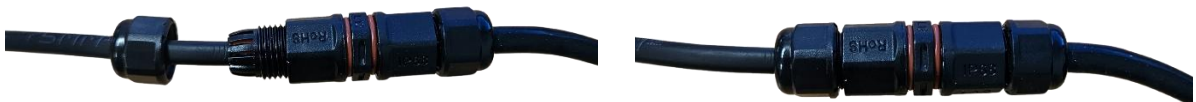

SOLAR POWERED SKYLIGHT MODULE PROGRAMMING

1. Press and hold the solar panel's "programming key" for x5 seconds located on the underside of the solar panel.



2. The indicator light will flash slowly

3. On the remote, select which channel you would like the skylight programmed to, then press up on the remote. *(this needs to be done within x15 seconds)*

4. The indicator on the solar panel will then flash x3 times quickly, programming is successful.

5. You can now use the remote to open and close the skylight



Note: To delete programming, follow steps above only press down on the remote not up to delete the programming.

Note: To change the direction for opening and closing on the remote, follow steps above only press the stop button.

Note: Solar panel will need regular cleaning as the build up of dirt will affect the sensitivity of the rain sensor and charging efficiency

Note: Wifi connection is not available on the solar powered skylights range

CONNECTING BLIND TO WIFI

Blinds (wifi connect blinds only)

1. Scan the QR code and download the Tuya – Smart Life, Smart Living mobile app and create an account
2. Connect the blind wifi module box to the blind's CAT6 networking cable
3. On the mobile app click the + button, then add device.
4. Scroll to “Small home appliances” and then select “Curtain motor”
5. On first time connecting a device you will need to configure the wifi to the app. Click “Configure wireless gateway”
6. Select the wifi you would like the device to be connected to and enter the wifi password.
7. Connect power to the blind
8. If indicator light on wifi module is blinking click “Confirm” (if not follow the app instructions to reset)
9. Select if blind wifi module is blinking fast or slow
10. Wait while app connects to the blind wifi module this can take approximately 30 seconds depending on the strength of the signal, keep phone close to blind wifi module whilst programming it.
11. Once successfully connected, rename the connected blind and then click “Done”
12. You can now open and close the blind through the mobile app.

**Wifi blind module input voltage 3.3V, working current <30mA, working temperature: -10°C to 55°C.*



CONNECTING ELECTRIC OPENING SKYLIGHT TO WIFI

Electric skylights *(with wifi connect controller only)*

1. Scan the QR code and download the Tuya – Smart Life, Smart Living mobile app and create an account
2. On the mobile app click the + button, then add device.
3. Scroll to “Small home appliances” and then select “Door/window (Wi-Fi)”
4. On first time connecting a device you will need to configure the wifi to the app. Click “Configure wireless gateway”
5. Select the wifi you would like the device to be connected to and enter the wifi password.
6. Ensure power is connected to the wall controller
7. Hold the stop button on the wall controller for 9 seconds, the buttons will turn red when you do this and they will start flashing red.
8. Select if wall controller is blinking fast or slow
9. Wait while app connects to the wifi wall controller this can take approximately 30 seconds depending on the strength of the signal, keep phone close to wifi wall controller whilst programming it.
10. Once successfully connected, rename the connected electric skylight and then click “Done”
11. You can now open and close the electric skylight through the mobile app.

Note: If you have trouble connecting device or it isn't as responsive when using the app, it will mainly be because of a weak Wi-Fi connection. You may need to increase the signal by adding Wi-Fi extenders to your home.

Note: For trouble shooting if the device isn't connecting follow the app instructions to reset and or connect via a mobile hotspot for initial setup.



Skylight shaft cladding

Skylights shafts can be cladded with many different claddings. The most common to draw in maximum light into the room is plasterboard. It is important to leave a 5mm gap in between the skylight frame and or 10mm gap (from glass for frameless shafts). This is to create a thermal break and reduce condensation from glass running down the shaft cladding of high humidity areas or where internal and external temperatures may vary dramatically. For best results when plastering the shaft use tear away beads at the top and plaster beads for internal corners to create sharp shaft lines.

Wet area installations additional information

If skylight is being installed in a wet area such as a bathroom it is advised not to be installed directly over a shower. An additional ducted exhaust fan is advised to be installed in the shaft where a skylight is installed in a wet area.

Note: Vivid Skylights does not warrant and does not recommend the installation of skylight blinds in high moisture areas such as a bathrooms and laundries which can cause the blind to fabric to malfunction over time.

FLYSCREEN INSTALLATION

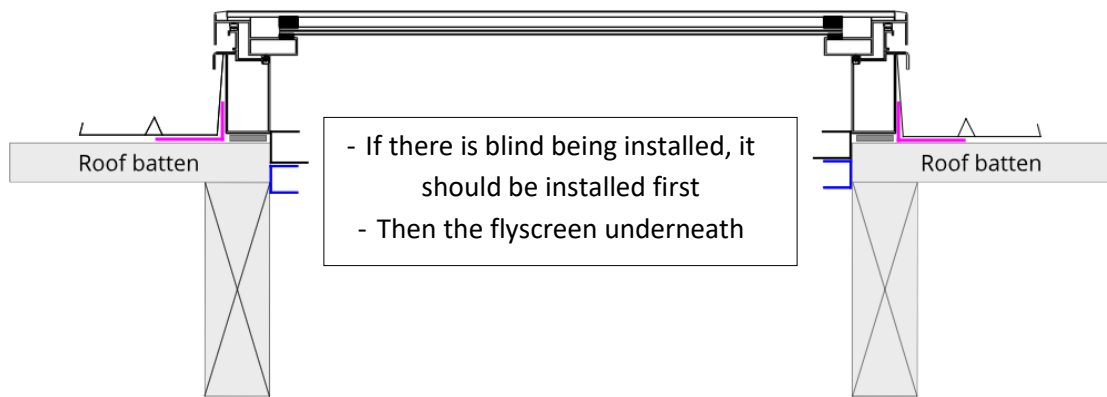

1. Slide across to unlock, to then be able to remove the inner screen section

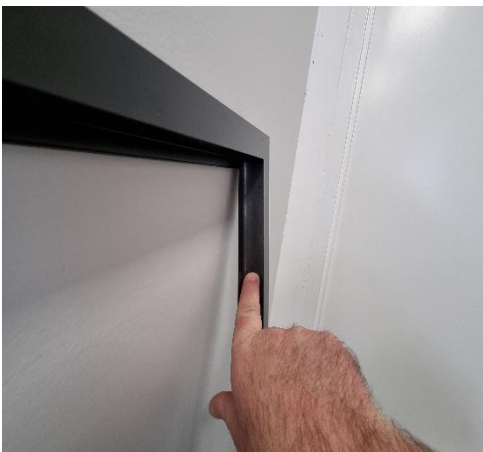

2. Fix x4 screws through the flyscreen frame into the shaft of the skylight (before plastering shaft).

3. Re-insert inner screen section into flyscreen frame and slide lock across to secure into position.



TROUBLE SHOOTING

1. Electric skylight wall controller issues?

Switch power off to wall controller for 1 minute then turn back on and follow steps to delete the existing programming and then follow steps to reprogram the wall controller. Checkout a quick Youtube video on how to do this <https://youtube.com/shorts/XugHUA9Z3ZQ?feature=share>

2. Electric skylight is vibrating or motor sounds like it's struggling to open and close the skylight?

The gas strut arms that hold the skylight up most likely have dust build up on them from the installation or dust build up over time since install, clean gas strut whilst in open position, then spray WD-40 lubricant along the gas strut arm that goes inside the other. Open and close the skylight a couple of times.

If the problem persists further investigation is required such as whether there is adequate power supply or any obstructions in the way slowing down the opening of the skylight.

3. Electric skylight remote not working?

Check power is connected to the skylight. Follow the steps to reset the programming and try again. If there is another skylight/s nearby they need to be able to be switched off individually with an isolator switch as when trying to program it with the remote it will get confused on which skylight is being programmed.

When programming a skylight follow instructions thoroughly and allow time between pressing buttons especially at the end as the skylight will take a few seconds to register the programming before you can use it.

Checkout a quick Youtube video on how to do this <https://youtube.com/shorts/TRE6JuIn0Zs?feature=share>

When using the remote allow a few seconds when pressing the button for the skylight to open and close, don't continually press buttons as it will cause the skylight to reprogram. If this happens you will need to delete the programming and reprogram the remote.

4. Rain sensor not working?

For an initial installation, you need to leave the sensor out in the sun for a couple of hours so the rechargeable battery can charge. Only place sensor on roof after programming it, mount it where it receives direct sunlight as well is in close proximity to where the internal wall controller is located. Try deleting memory on the wall controller and reprogram it.

5. Blind not closing or blind only partially closing?

1. Check power is connected to the blind. Follow the steps to reset the programming and try again. If there is another blind/s nearby they need to be able to be switched off individually with an isolator switch as when trying to program it with the remote it will get confused on which blind is being programmed.

2. When programming a blind follow instructions thoroughly and allow time between pressing buttons especially at the end as the blind will take a few seconds to register the programming before you can use it.

3. When using the remote allow a few seconds when pressing the button for the blind to open and close, don't continually press buttons as it will cause the blind to reprogram and will then stop at incorrect places. If this happens you will need to delete the programming and reprogram the remote.

4. If blind is only partially opening it may have been reset due to multiple buttons being pressed during its operation. To reset the blind turn power off for 20 seconds then back on again, press the UP and then STOP button on the remote continuously and it will make slight increments until it's in the fully open position. Blind will now be reset for normal operation.

Checkout a quick Youtube video on how to do this <https://youtube.com/shorts/pwntz2aLtQg?feature=share>

VIVID SKYLIGHT WARRANTY INFORMATION

Openwide Homes Pty Ltd ACN 625 508 045 provides that this product is covered by a 10-year leak-free warranty on fixed skylights and 1 year for electric motors and rain sensors of opening skylights and electric blinds from the date of purchase, against faulty workmanship and/or materials. To make a claim, return the faulty item together with proof of purchase of an invoice or sales receipt to the place of purchase. Any handling and transportation costs (and other expenses incurred in claiming this warranty) are not covered by this warranty and will not be borne by Openwide Homes. The replacement product or part or repaired product will be made available for your collection at an address nominated by Openwide Homes. If your claim is not dealt with by your retailer, contact Openwide Homes using the details below. Where a valid warranty claim is made by the original consumer of the product Openwide Homes will replace the defective product or repair the fault. Where the product is repaired, Openwide Homes may use refurbished parts. This warranty does not cover normal wear and tear, misuse or abuse. Openwide Homes has no other liability under this warranty. The benefits to be given by this warranty are in addition to other rights and remedies of the consumer under a law in relation to the goods to which the warranty relates. Our goods come with guarantees that cannot be excluded under the Australian Consumer Law. You are entitled to a replacement or refund for a major failure. You are also entitled to have the goods repaired or replaced if the goods fail to be of acceptable quality and the failure does not amount to a major failure.

What is not covered

- 1.1 This warranty only covers defects that have arisen from the products manufacture
- 1.2 This warranty will only apply if the product has been installed by a licenced roof plumber and carpenter following our strict installation instructions and maintained in accordance with Openwide Homes maintenance guidelines. Without limiting the foregoing of defect claims to which has resulted from directly or indirectly the products installation carried out differently to Openwide Homes installation guidelines, good workmanship, installation of product outside of recommended locations and conditions, normal wear and tear, use of not genuine Openwide Homes replacement products or components, power supply, transportation and or any inappropriate or insufficient care handling and storing the product. In addition the warranty will not apply to any defects which arise from neglect including but not limited to failure to maintain and/or service the product as described in the installation and maintenance guide. All such instructions can be found on the website www.vividskylights.com.au.
- 1.3 Normal gaining of surfaces as a result from weathering or effects caused by environmental, atmospheric or corrosive substances including but not limited to such as cleaning agents that may cause a reaction to the components of the product are not covered by this warranty
- 1.4 Glass corrosion due to debris or standing water on glass are not covered by this warranty
- 1.5 This warranty does not cover without limitation problems with product damage, malfunction, restricted or reduced function and or water leakage. Which were resulting factors from accidents, blocking or alike of branches, twigs, leaves, ice or snow etc, including without limitation poor workmanship, building design, building movement, acts of God/nature, where applications have high humidity without appropriate ventilation or humidity control, water penetration from ice damming, variations in glass coloration, damage or other issues caused by adverse environmental conditions including to but not limited to acid rain.
- 1.6 The warranty excludes any claim relating from condensation water damage which may occur as a result of humidity inside or outside of a building or variation between indoor/outdoor temperatures this is not a defect.
- 1.7 This warranty specifically excludes any leaks due to any of the following: re-roofing without using a licenced roof plumber, Openwide Homes approved flashings, capping and or sealants. Claims relating to a product left open during rain or other, moisture penetration at seams in the roof deck, incorrect installation of the product, rough opening sizes other than those issued in the Openwide Homes installation instructions, non or improper maintenance of the product or installation, accidental breakage, misuse, abuse, poor building design and construction, act of nature/God, corrosive environmental factors including acid rain and or any other factor unrelated to the original installation guidelines of the product are not covered by this warranty
- 1.8 Extreme weather conditions such as severe rain, hail, lightning, snow, large roof areas above a roof window (water should be diverted away from roof window), roof pitches above 45 degrees are not covered by this

warranty. In case of flood and water overflowing the roof window, this is considered acts of nature/God and is not covered by this warranty.

- 1.9 This warranty also does not cover claims relating to the following:
- a. Discoloration of parts that are not visible by general use
 - b. Any change of colour and fading whether or not it has been caused by sun/acid rain/salty rain/condensation/incorrect cleaning products used or any other conditions that may have caused a changing effect
 - c. Minor variations/imperfections in glass that do not affect the product performance or obscure vision
 - d. Any reduction of efficiency of the product such as glazing values and tolerances
 - e. Imperfections in the glass which were present at the time of delivery or have arisen during the warranty period and which do not impair the view
 - f. Corrosion due to industrial and household chemicals
 - g. Exposure to cleaning of other building material near such as but not limited to acid washing bricks and or pressure cleaning of roof etc
 - h. Corrosion of electronic devices due to adverse environmental factors
 - i. Claims in regard to where any film has been applied to the glass surface
 - j. Rain sensor should not be solely relied upon to close skylight during rain, storm or act of God in case the batteries are flat. Skylights should always be closed before exiting the building.
 - k. In the event that a malfunction of the rain sensor occurs by not signalling to the wall controller to close or flat batteries. No property damages claims due to skylight remaining open will be warranted. Always keep skylight closed when rain/storm is forecasted and when exiting the building.
2. The warranty does not include the following re-installation labour or other damages caused by reinstallation, dents, cosmetic, superficial or other damages that do not impede the reasonable operation of the roof window.
3. The warranty will be voided in the event unauthorized repairs have taken place.
- 4.1 All costs and expenses relating to the replacement of the product will be borne by the end-user such as but not limited to shipping costs, re-installation, speciality equipment such as scaffolds, boom, crane platforms etc and are not covered by this warranty.
- 4.2 A call out fee will apply to the end user if a site inspection is required that will be paid in advance prior to the site visit (this fee will be dependent on site location, only site inspections in Melbourne are able to be conducted). If it is determined that the installation is correct and the product is faulty this call out fee will be refunded to the end user. For a site inspection to be completed appropriate fall protection/scaffold or access will need to be provided by the end user prior to the inspection taking place.
5. The end user is solely responsible for maintaining and minimising water damage or any other damage that the product may cause, including all costs and expenses associated with temporary covering the roof opening whilst the product is repaired or replaced.
6. For all product related enquires and warranties please email sales@vividskylights.com.au
7. Warranty and installation guides are subject to change without notice.

Product returns/exchanges:

Vivid Skylights will only consider accepting product returns and or exchanges within 14 days of product pickup or delivery. Vivid Skylights will not accept “change of mind” returns. Any return or exchange must not have been installed and still be in original packaging and undamaged box with all product parts accounted for, a 20% restocking fee will be applicable for returned products.

Transportation costs of all returned or exchanged products will be the sole responsibility of the customer.



SUPPLIED INSTALLATION COMPONENTS AND TILED FLASHING IF APPLICABLE



X18 self-tapping screws



X16 timber screws



**x1 electrical wall bracket
(opening skylight only)**



X6 brackets



X1 top roof flashing



X1 bottom flashing



X2 side flashings